

POLYROM Isoclick sheet - 40mm

Product Technical Manual



INDEX

Introduction	3
POLYROM Isoclick sheet - Mechanical properties	4
General and Installation guidelines	4
Wind Loading	6
Installation guidelines	7

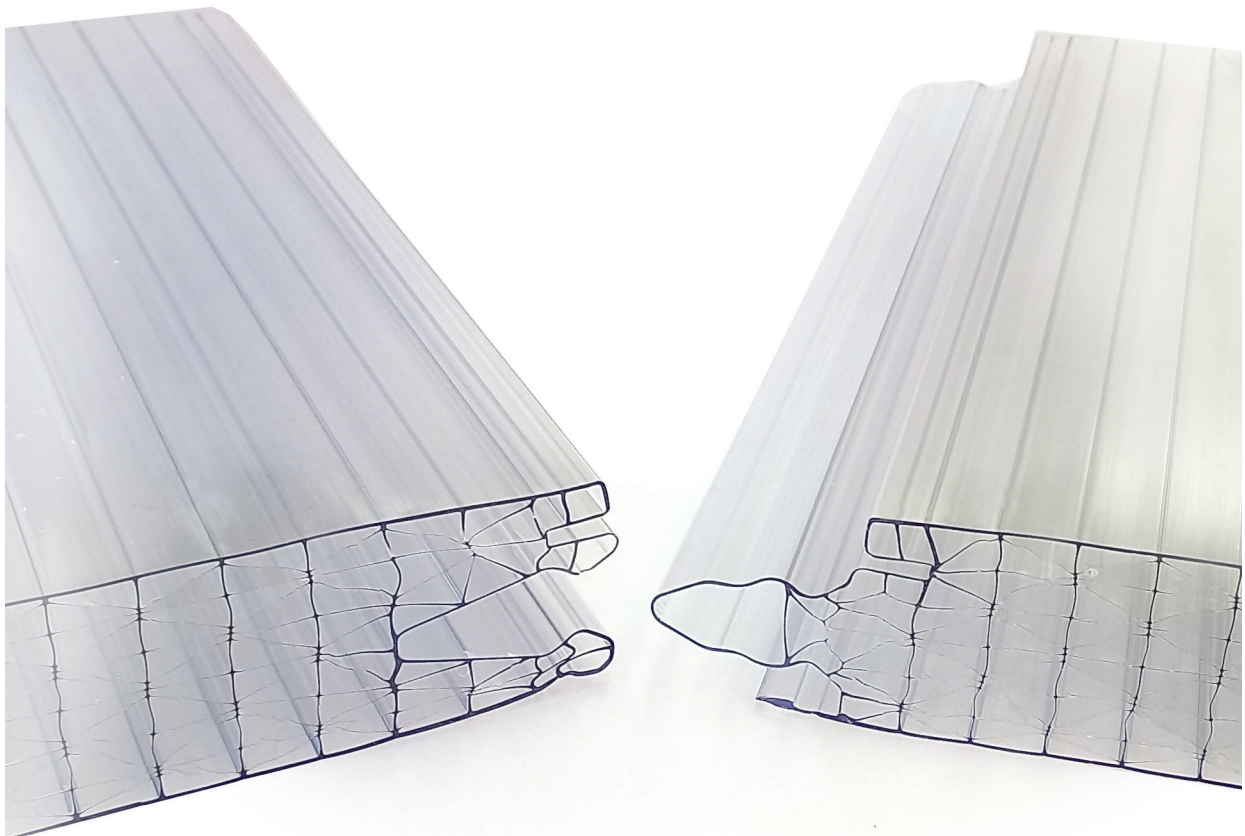

Polycarbonate is a unique engineering thermoplastic which combines a high level of mechanical, optical and thermal properties. When extruded in multi-wall sheet form, its optical and impact properties in particular render this material a strong candidate for a wide range of glazing applications.

POLYROM Isoclick sheet

Polyrom Isoclick sheet is a cellular board with 13 walls, impact resistance, with a high thermal insulation capacity that leads to energy savings and with a profiled V-joint connection, including a groove for double sided tie on the inside. This double joining system that includes groove at the edge of the sheets eliminates the need for vertical profiles, thereby saving costs and enhancing aesthetics.

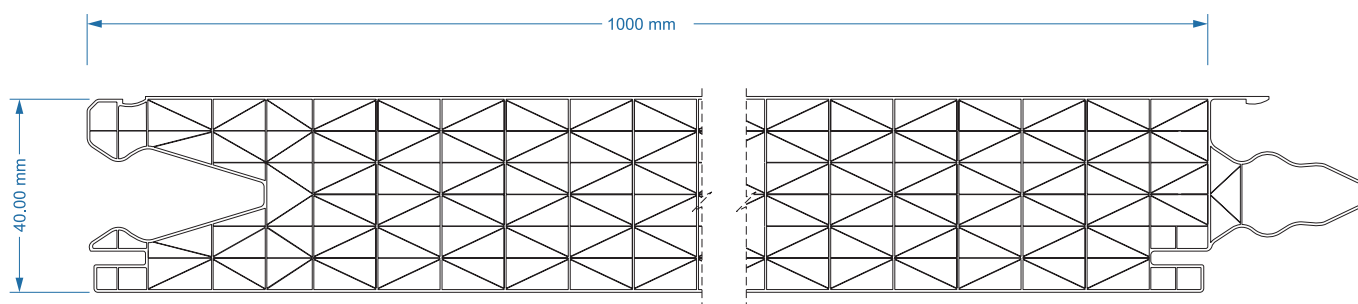

POLYROM Isoclick sheet offers:

- Unique structure, in X and 13 walls
- UV protected outer surface
- Good light transmission and light diffusion characteristics
- Extremely high stiffness
- Superb thermal insulation of 0,98 W/m² K
- High impact strength
- Long-term written limited warranty weather resistance
- Simple, easy and fast installation
- Wide range of colors and aesthetic effects

Property Profile	Value	Test Method
Panel width ctc	1000 mm ±2,5 mm	
Standard length	≤6 m -0 + 20 mm ≤6 m -0 + 30 mm	
Panel total thickness	40 mm ±1 mm	
Weight	4,00 kg / m ² ±5%	
Fire Rating	B, S2, d0	EN13501
Sound insulation	≤ 27 Db	DIN 52210-75
Hail impact	Diam. 20 mm V≥21m/s	Testul TNO
Temperature resist.	-40°C până la +120°C	UL 746 BEN
U-Value, k	0,98 W/m ² K	ISO 10077 (EN673)
Coeff. of linear thermal expansion	7 x 10 ⁻⁵ 1/°C	DIN 53752

Color	Light Transmission	Test Method
Clear	59%	EN 410
Opal white	50%	EN 410

POLYROM Isoclick sheet - Mechanical properties

Impact Strength

POLYROM Isoclick sheet has outstanding impact performance over a wide temperature range of -40°C to +120°C. The product has been shown capable of withstanding many kinds of extreme weather, storms, hailstones, snowfall and ice formation.

UV protection

POLYROM Isoclick sheet has one proprietary UV protected surface to help protect the system against the degrading effects of ultra violet radiation of sunlight and promotes long-term optical quality under many kinds of severe weather conditions. This UV protected surface, indicated on the masking, should always face outwards.

Garanția

ESPRIT GROUP SRL offers a 10 (ten) year guarantee for the POLYROM Isoclick sheet against discoloration, loss of light transmission capacity and loss of impact resistance due to exposure to atmospheric factors.

General and Installation guidelines

Thermal insulation

The multi-wall structure of POLYROM Isoclick sheet offers potential advantages where thermal insulation is a major consideration. The amount of energy transmitted through the material per square meter and per degree temperature difference, referred to as U-Value, is only 0.98 W/m²K.

Temperature resistance

POLYROM Isoclick sheet is characterized by its excellent retention of impact strength and stiffness at elevated temperatures, even over an extended period. POLYROM Isoclick sheet has a continuous use temperature rating of -40°C up to +120°C.

Fire test performance

POLYROM Isoclick sheet with 13 walls has good characteristics in terms of its fire performance according to the various European reference tests on fire resistance. For details, contact your authorized distributor.

Storage

POLYROM Isoclick sheet should be stored and protected against atmospheric influences like sun, rain, etc. Care should be exercised when handling and transporting POLYROM Isoclick sheet in order to prevent scratches on the panel surface and damage to the panel edges.

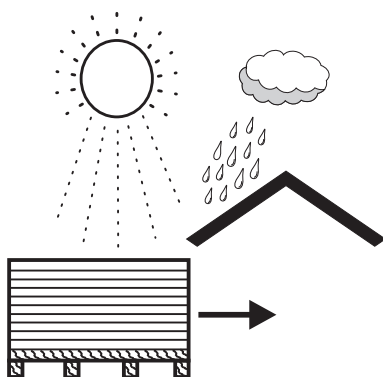

Sawing

POLYROM Isoclick sheet can be cut easily and accurately with most standard workshop equipment. This includes common circular, hand and hacksaws both with finetoothed blades. The panel should be clamped to the worktable to avoid undesirable vibration and the sawdust should be blown out of the channels.

Sealing recommendations

In order to minimize moisture build-up and dust contamination inside the channels, edge sealing of the open ended channels is very important.

Standard glazing

For standard glazing applications it is generally recommended to seal the top end channels with an impermeable tape and the bottom end channels with an anti-condensation venting tape. A clearance between the bottom panel end and the sash profile platform helps allow for condensation drainage.

Specific conditions

In extremely dusty environments such as sawmills, welding stations, etc., it is usually advisable to seal both the top and bottom channel ends with an impermeable tape.

Thermal expansion allowance

Take into account a clearance of approximately 3mm per linear meter between panel top edge and top glazing profile platform, and between the first and last panel side and side glazing profile platform. This thermal expansion clearance is already taken into account when using the special developed top and bottom glazing profiles indicated in this chapter.

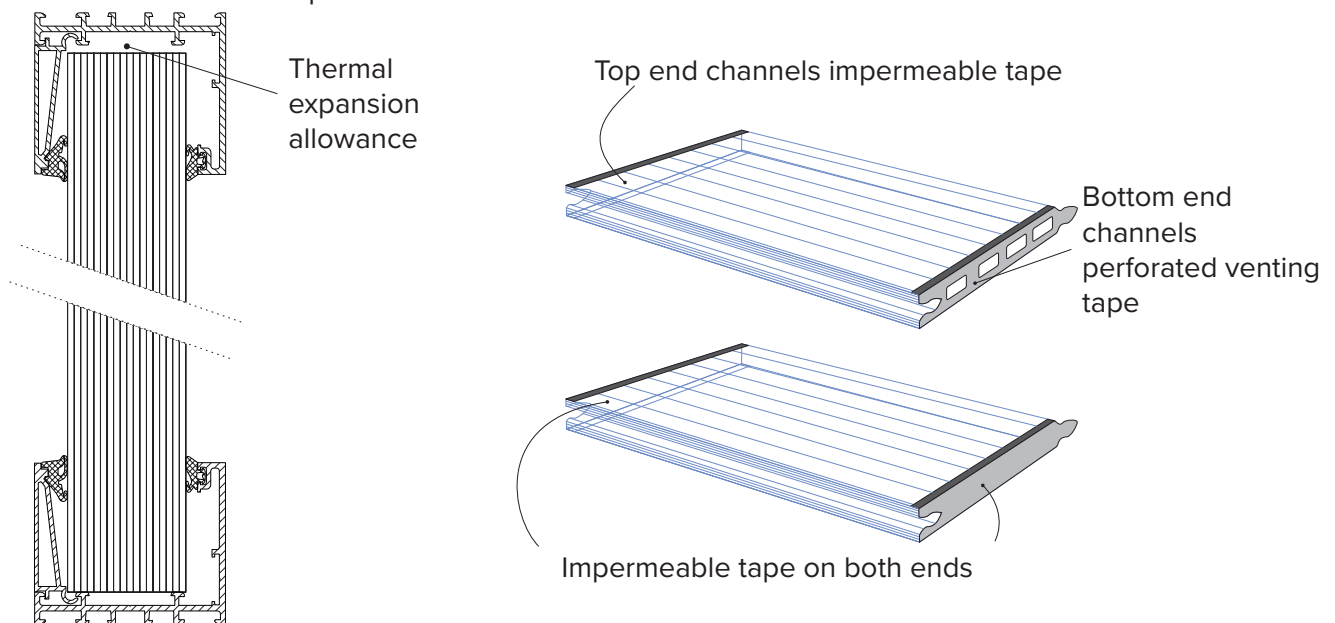

Typical glazing detail - Thermoplastic/alu glazing profile

Cleaning Recommendations

These cleaning recommendations apply to all POLYROM polycarbonate sheet products, including, but not limited to, POLYROM solid sheet and signs, POLYROM multiwall sheet. Periodic cleaning using correct procedures can help to prolong service life. For cleaning, it is recommended that the following instructions be adhered to:

Cleaning Procedure for Small Areas – Manual

1. Gently wash sheet with a solution of mild soap and lukewarm water, using a soft, grid-free cloth or sponge to loosen any dirt or grime.
2. Fresh paint splashes, grease and smeared glazing compounds can be removed easily before drying by rubbing lightly with a soft cloth using petroleum ether (BP65), hexane or heptane. Afterwards, wash the sheet using mild soap and lukewarm water.
3. Scratches and minor abrasions can be minimized by using a mild automobile polish. We suggest that a test be made on a small area of POLYROM sheet with the polish selected and that the polish manufacturer's instructions be followed, prior to using the polish on the entire sheet.
4. Finally, thoroughly rinse with clean water to remove any cleaner residue and dry the surface with a soft cloth to prevent water spotting.

Cleaning Procedure for Large Areas - Automated

1. Clean the surface using a high-pressure water cleaner (max. 100bar or 1,450psi) and/or a steam cleaner. We suggest that a test be made on a small area, prior to cleaning the entire sheet.
2. Use of additives to the water and/or steam should be avoided.

Other Important Instructions for All POLYROM sheets:

- Never use abrasive or highly alkaline cleaner on POLYROM polycarbonate sheets.
- Never use aromatic or halogenated solvents like toluene, benzene, gasoline, acetone or carbon tetrachloride on POLYROM polycarbonate sheets.
- Use of incompatible cleaning materials with POLYROM sheet can cause structural and/or surface damage.
- Contact with harsh solvents such as methyl ethyl ketone (MEK) or hydrochloric acid can result in surface degradation and possible crazing of POLYROM sheet.
- Never scrub with brushes, steel wool or other abrasive materials.
- Never use squeegees, razorblades or other sharp instruments to remove deposits or spots.
- Do not clean POLYROM polycarbonate in direct sunlight or at high temperatures as this can lead to staining.
- For all mentioned chemicals consult the manufacturer's material safety datasheet (MSDS) for proper safety precautions.
- Cleaners and solvents generally recommended for use on polycarbonate are not necessarily compatible with the UV-protected surfaces of POLYROM multiwall sheets.
- Do not use alcohols on the UV-protected surfaces of POLYROM polycarbonate sheet

Wind Loading

Dynamic wind pressure

The wind speed is used to determine the actual loading upon the glazing panels. In mathematical terms, the pressure loading is calculated by multiplying the square of the design wind speed by 0.613.

$$q = KV^2 \quad \text{Where:}$$

q = dynamic wind pressure in N/m²

K = 0.613

V = design wind speed in meters/second

Values of p in SI units (N/m²)

Wind speed, m/s	Wind pressure, N/m ²
10	61
15	138
20	245
25	383
30	552
35	751
40	981
45	1240
50	1530
55	1850
60	2210
65	2590

The Beaufort scale transforms wind into static pressure

Wind	Light	Moderate	Strong	Storm
Speed (km/h)	20	40-60	80 - 100	120 – 140
Speed (m/sec)	6	11 – 17	22 - 28	33 – 39
Static pressure (N/m ²)	20	80 - 170	300 - 480	680 -950

Pressure coefficient

To allow for local fluctuations in the acceleration/deceleration of the wind by building or glazing geometry, it is necessary to include an appropriate pressure coefficient. Determining pressure coefficients requires knowledge of

- Form and type of building
- Height of glazing
- Shape of glazing e.g.
 - flat vertical
 - inclined roofing
 - curved glazing

The wind loading is obtained by multiplying the dynamic wind pressure by the pressure coefficient. The total wind loading can be positive indicating a wind pressure load or negative indicating a wind suction load. Detailed pressure coefficient values can be found in the appropriate national building norms.

Installation guidelines

Vertical wall glazing

This chapter illustrates some glazing proposals using aluminum profiles that allow quick and easy assembly. POLYROM Isoclick sheet can be installed either from inside the building or from the outside.

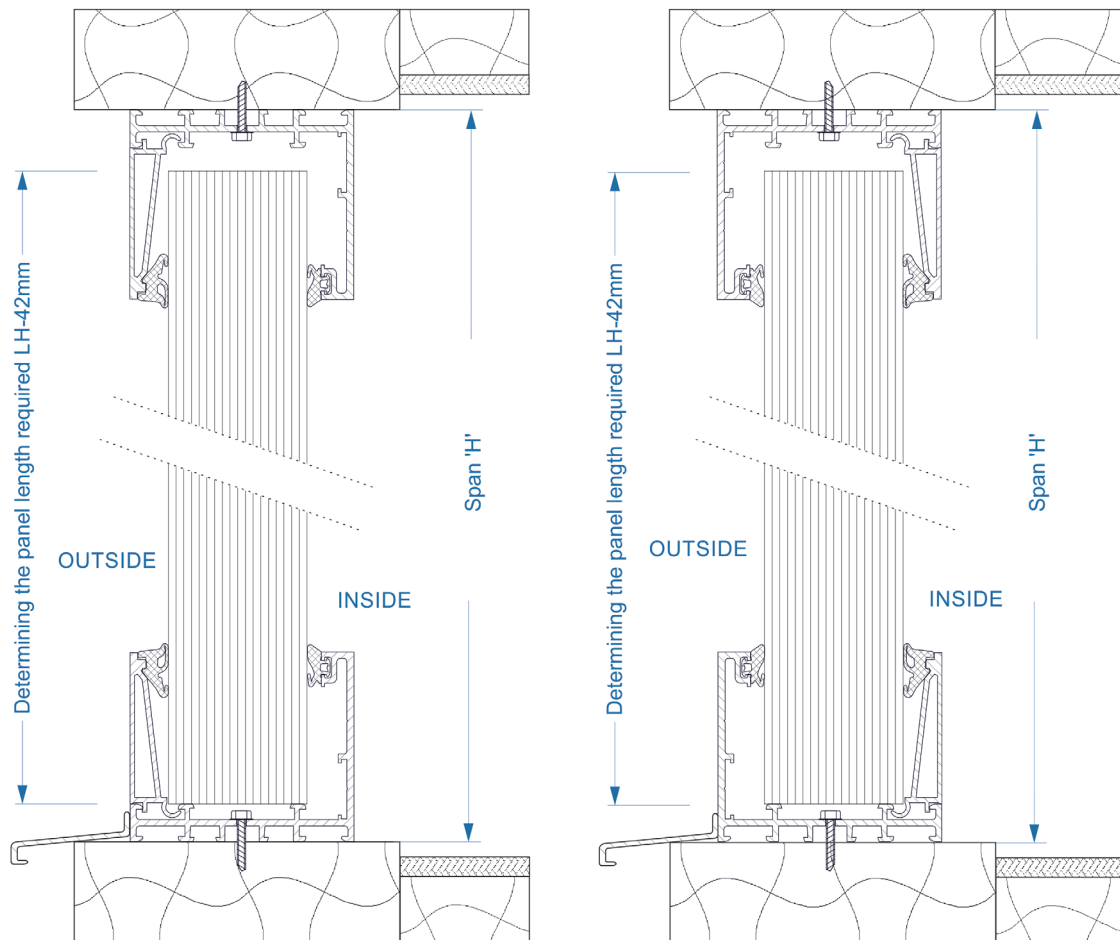

Determining the panel length required $L = H - 42 \text{ mm}$

Maximum recommended span 'H'

POLYROM Isoclick sheet glazing recommendations without intermediate purlins.

Distance between top and bottom glazing profiles	Maximum allowable Wind pressure
2000 mm	1900 N/m ²
2200 mm	1750 N/m ²
2400 mm	1600 N/m ²
2600 mm	1450 N/m ²
2800 mm	1350 N/m ²
3000 mm	1200 N/m ²
3200 mm	1050 N/m ²

When the glazing height exceeds the maximum recommended span 'H', intermediate horizontal purlins should be used to support the POLYROM Isoclick sheet. POLYROM Isoclick sheet may be fixed to these purlins using special non-rusting metal fastening clips positioned in the double sided tie on both panel sides. The distance between the horizontal intermediate purlins should not exceed the maximum recommended span dimensions 'P' as indicated in the table below.

Maximum recommended span 'P'

POLYROM Isoclick sheet glazing recommendations with intermediate purlins and clip length of 100 mm.

Distance between Intermediate purlins	Maximum allowable Wind pressure
2000 mm	1800 N/m ²
2200 mm	1650 N/m ²
2400 mm	1500 N/m ²
2600 mm	1375 N/m ²
2800 mm	1250 N/m ²
3000 mm	1100 N/m ²
3200 mm	1000 N/m ²

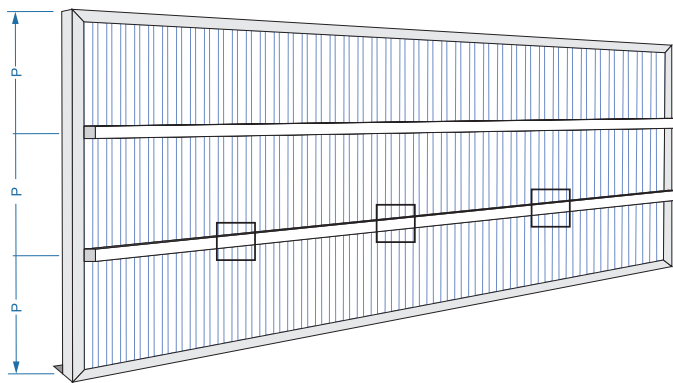

Purlin distance 'P'

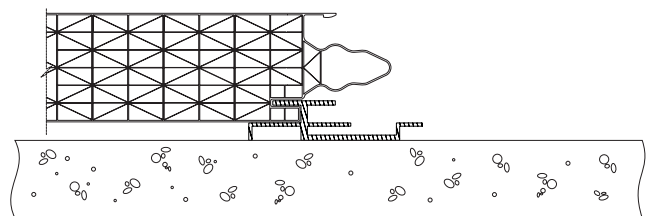

Slide metal fastener clip in place

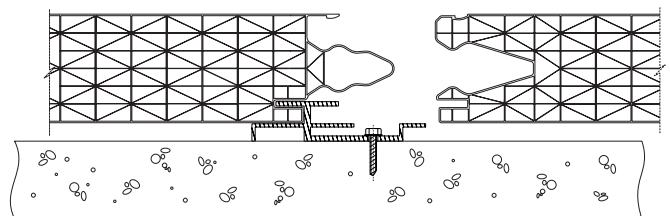

Bolt clip to purlin

Metal fastener clip

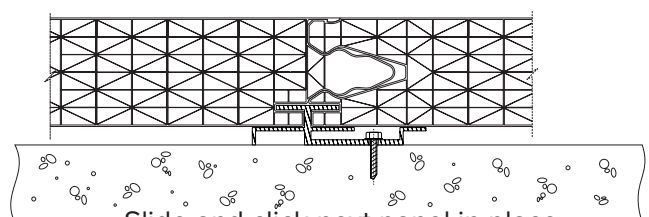
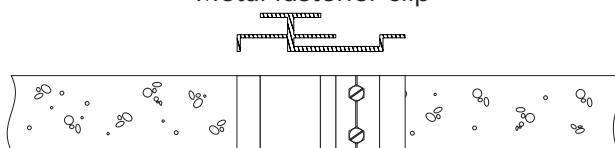

Slide and click next panel in place

Profile system - POLYROM Isoclick

For the POLYROM Isoclick sheet, Esprit Group SRL is able to supply a anodized aluminum profile system including corner connectors. The profile system has a thermal break to ensure thermal insulation of the total system. The profile system exists out of a L-shape base profile, after installing the POLYROM Isoclick sheet the profile is completed with a “closing” profile. This allows full freedom of movement during installation of the POLYROM Isoclick sheet. For additional information, please contact the Esprit Group SRL representative.

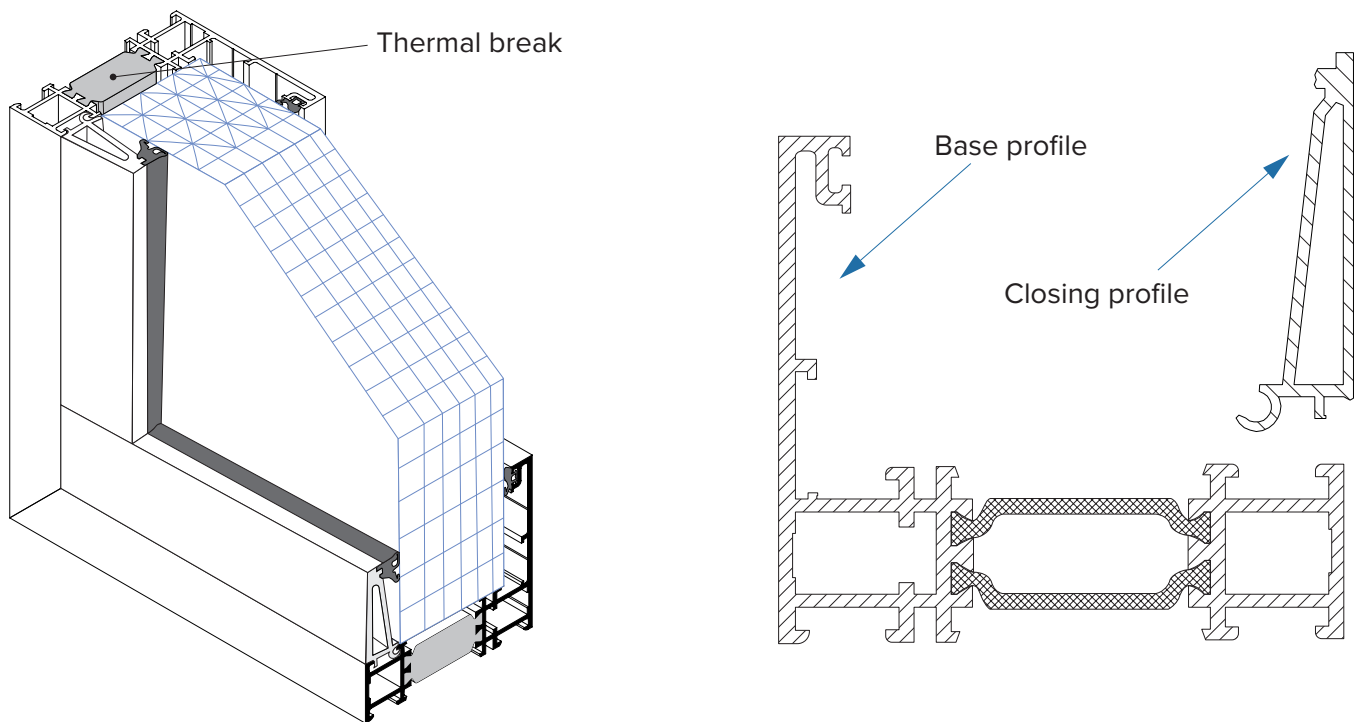

DISCLAIMER: THE MATERIALS, PRODUCTS AND SERVICES OF ESPRIT GROUP SRL, ITS SUBSIDIARIES AND AFFILIATES (“SELLER”), ARE SOLD SUBJECT TO SELLER’S STANDARD CONDITIONS OF SALE. ALTHOUGH ANY INFORMATION OR RECOMMENDATION CONTAINED HEREIN IS GIVEN IN GOOD FAITH, SELLER MAKES NO WARRANTY OR GUARANTEE, EXPRESS OR IMPLIED, (i) THAT THE RESULTS DESCRIBED HEREIN WILL BE OBTAINED UNDER END-USE CONDITIONS, OR (ii) AS TO THE EFFECTIVENESS OR SAFETY OF ANY DESIGN INCORPORATING SELLER’S PRODUCTS, SERVICES OR RECOMMENDATIONS. EXCEPT AS PROVIDED IN SELLER’S STANDARD CONDITIONS OF SALE, SELLER SHALL NOT BE RESPONSIBLE FOR ANY LOSS RESULTING FROM ANY USE OF ITS PRODUCTS OR SERVICES DESCRIBED HEREIN.

Each user is responsible for making its own determination as to the suitability of Seller’s products, services or recommendations for the user’s particular use through appropriate end-use testing and analysis. Nothing in any document or oral statement shall be deemed to alter or waive any provision of Seller’s Standard Conditions of Sale or this Disclaimer, unless it is specifically agreed to in a writing signed by Seller. No statement by Seller concerning a possible use of any product, service or design is intended, or should be construed, to grant any license under any patent or other intellectual property right of Seller or as a recommendation for the use of such product, service or design in a manner that infringes any patent or other intellectual property right. POLYROM is a trademark.